

AN10997

TDA8035 Smart Card Reader

Rev. 1.2 — 4 April 2012

Application note

Document information

Info	Content
Keywords	TDA8035HN, Smart Card Interface, Pay TV, STB, NDS, ISO 7816-3
Abstract	<p>This application note describes the smart card interface integrated circuit TDA8035HN.</p> <p>This document helps to design the TDA8035HN in an application. The general characteristics are presented and different application examples are described.</p>



Revision history

Rev	Date	Description
1.2	20120404	Entering test mode description
1.1	20120124	PRESN pull-up resistor calculation added
1.0	20110401	Initial version

Contact information

For additional information, please visit: <http://www.nxp.com>

For sales office addresses, please send an email to: salesaddresses@nxp.com

1. Introduction

1.1 Presentation

The TDA8035HN is a smart card interface device forming the electrical interface between a micro controller and a smart card. This device mainly supports asynchronous cards (micro controller-based IC cards).

The electrical characteristics of the TDA8035HN are in accordance with NDS requirements (IRD Electrical Interface Specifications doc n° LC-T056) and also comply with ISO7816-3 for class A, B and C cards.

The TDA8035HN can be used in various applications such as pay-TV, Point-Of-Sale terminals (POS), public phones, vending machines, and many conditional access applications (i.e. Internet,..).

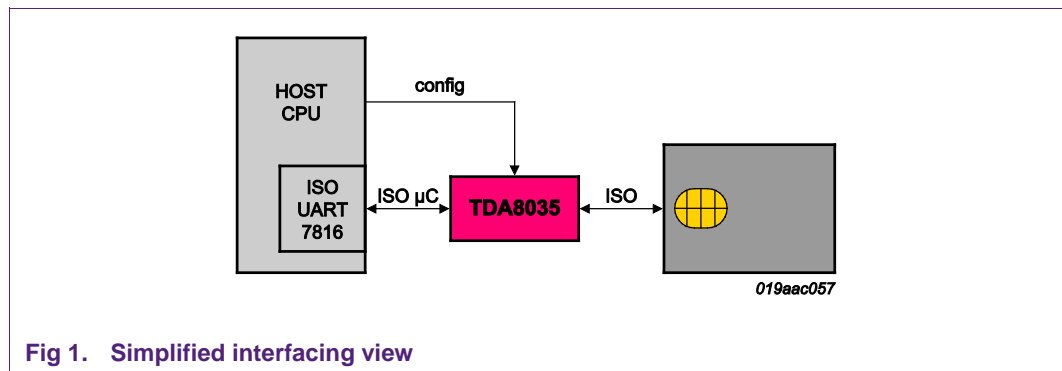

Fig 1. Simplified interfacing view

In the whole document, the TDA8035HN will be referred as TDA8035.

2. Power supply

2.1 Power supply pins

Two input pins are used to supply the TDA8035: $V_{DD(INTF)}$ and V_{DDP} . One voltage is internally generated by the TDA8035 and used for the internal digital part. It is available on V_{REG} pin for external decoupling.

$V_{DD(INTF)}$ is dedicated to the interface supply. All signals which are interfaced with the host are referenced to this voltage supply.

The next table describes all the pins that must be referenced to $V_{DD(INTF)}$.

Table 1. $V_{DD(INTF)}$ referenced pins

Pin name	Comment
IOUC	Smart card data. Controlled by the microcontroller
PORADJ	External configuration of $V_{DD(INTF)}$ supervision threshold
CMDVCCN	Smart card activation. Controlled by a microcontroller GPIO
CLKDIV1	Control of the clock division. Can be controlled by the microcontroller or connected directly to GND or $V_{DD(INTF)}$
CLKDIV2	Control of the clock division. Can be controlled by the microcontroller or connected directly to GND or $V_{DD(INTF)}$
EN5V_3VN	Choice of the smart card voltage. Can be controlled by the microcontroller or connected directly to GND or $V_{DD(INTF)}$
EN1.8VN	Choice of the 1.8V smart card voltage. Can be controlled by the microcontroller or connected directly to GND or $V_{DD(INTF)}$
RSTIN	RST pin management. Controlled by a microcontroller GPIO
OFFN	Output to the host. Must be connected to the microcontroller and therefore have the same level
XTAL1	External oscillator, or crystal input
XTAL2	Crystal output
CS	Chip select signal
PRESN	Not connected to the microcontroller but reference to $V_{DD(INTF)}$. The smart card connector presence switch must use $V_{DD(INTF)}$
AUX1UC	Management of AUX1. Controlled by the microcontroller
AUX2UC	Management of AUX2. Controlled by the microcontroller

V_{DDP} is used to supply the DC/DC converter of the TDA8035 and the internal regulator used to generate V_{REG} .

V_{REG} supplies the core of the TDA8035. It is generated by the TDA8035. Its value is always 1.8 V.

2.2 Supply supervisor

2.2.1 Main principles

The TDA8035 supervises the voltage level of V_{REG} , V_{DDP} and $V_{DD(INTF)}$. For V_{REG} and V_{DDP} supervision, the threshold is internally fixed. For $V_{DD(INTF)}$, the threshold can be fixed either internally or externally using the PORAdj pin.

The following figure explains the supervision for all the supplies.

Then the table gives the threshold values for each input.

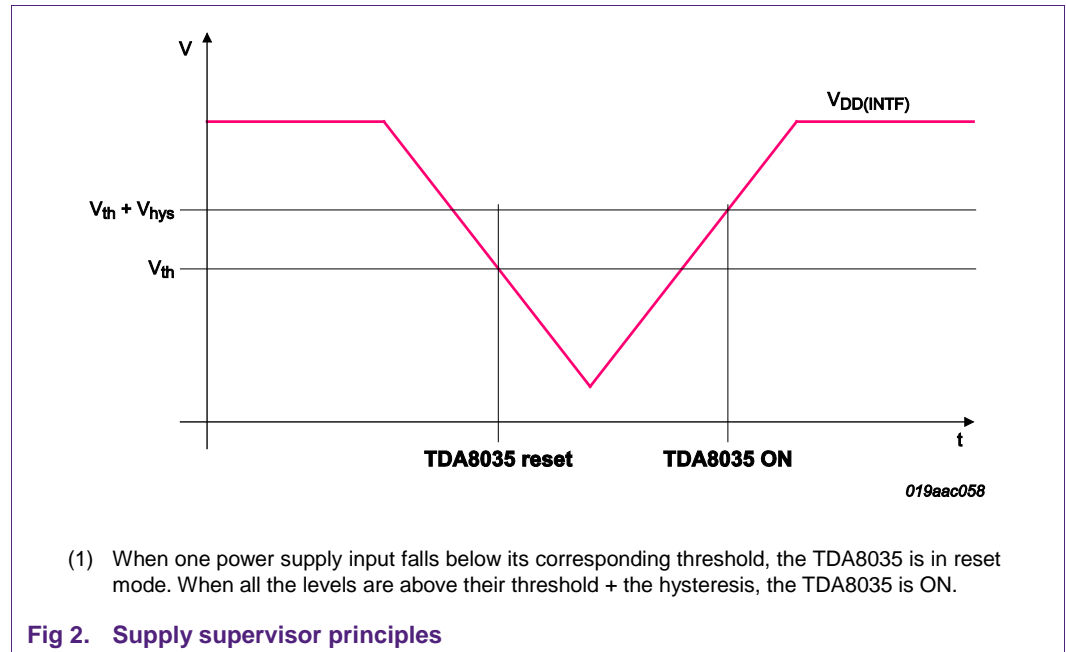

2.2.2 Supervision with PORAdj used

The TDA8035 allows to fix externally the threshold on $V_{DD(INTF)}$. This can be done by using an external resistor bridge on the PORAdj pin.

The supervision principle is given in the next two pictures:

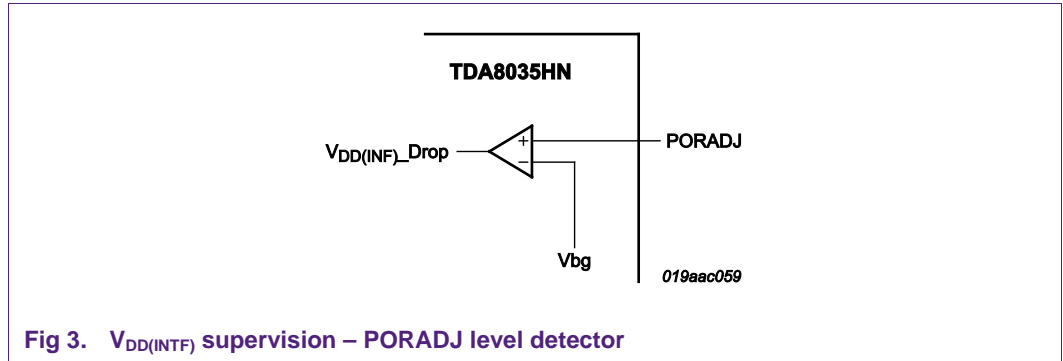

Fig 3. $V_{DD(INTF)}$ supervision – PORADJ level detector

The TDA8035 compares the pin voltage level on pin PORADJ to an internal voltage reference called V_{bg} .

When PORADJ falls below V_{bg} , the TDA8035 is reset:

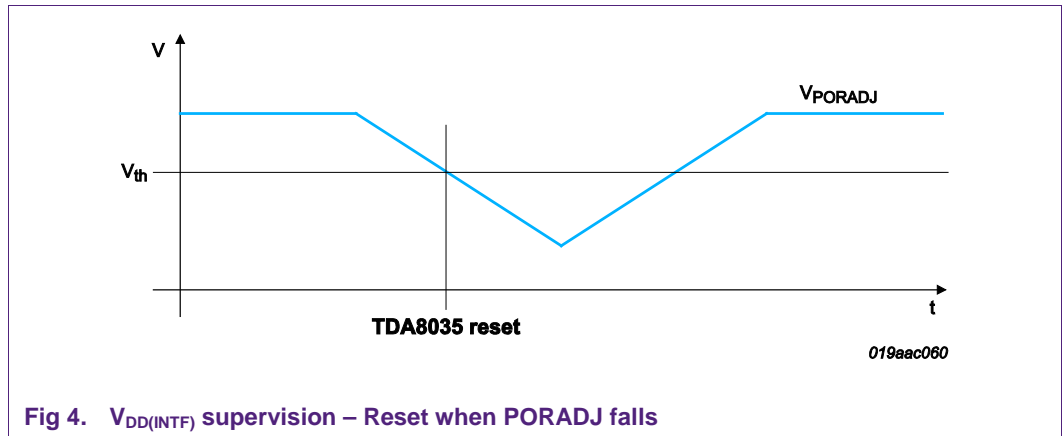

Fig 4. $V_{DD(INTF)}$ supervision – Reset when PORADJ falls

In order to set a specific supply supervisor value on $V_{DD(INTF)}$, a resistor bridge referred to $V_{DD(INTF)}$ must be connected to PORADJ:

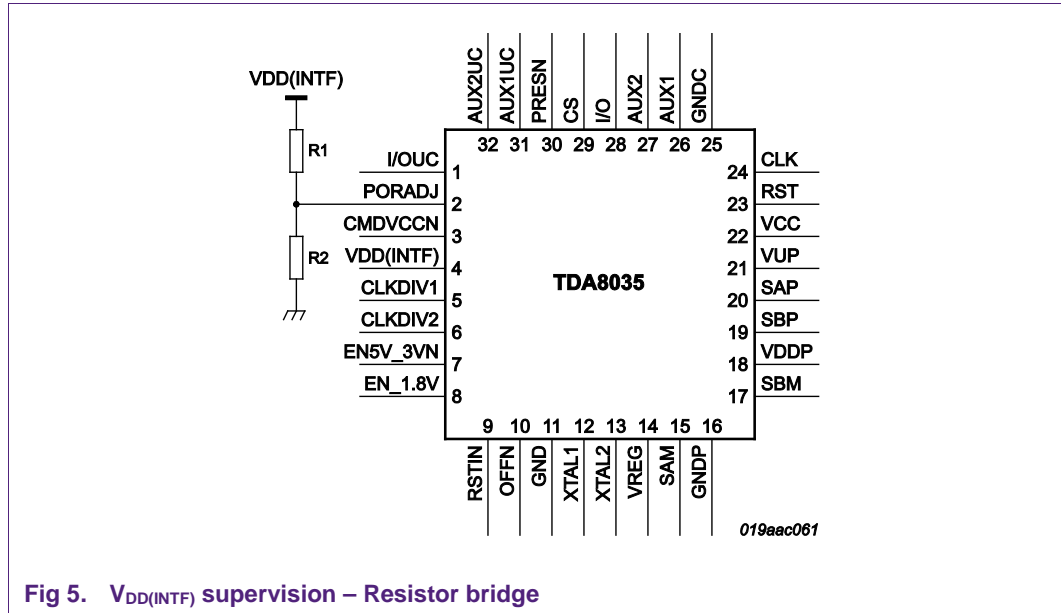

Fig 5. $V_{DD(INTF)}$ supervision – Resistor bridge

In this case $V_{PORADJ} = V_{DD(INTF)} \cdot R2 / (R1 + R2)$ and $V_{DD(INTF)}$ is monitored indirectly: the TDA8035 enters the reset mode when $V_{DD(INTF)} \cdot R2 / (R1 + R2)$ falls below V_{bg} .

This corresponds to a “virtual” threshold on $V_{DD(INTF)}$ which value is obtained when

$$V_{bg} = V_{DD(INTF)} \cdot R2 / (R1 + R2) \rightarrow V_{DD(INTF)} = V_{bg} \cdot (1 + R1/R2)$$

This virtual threshold is the V_{th} corresponding to $V_{DD(INTF)}$. This is called virtual as $V_{DD(INTF)}$ is never compared to V_{th} . Only V_{PORADJ} is compared to V_{bg} . The following drawing shows this behavior:

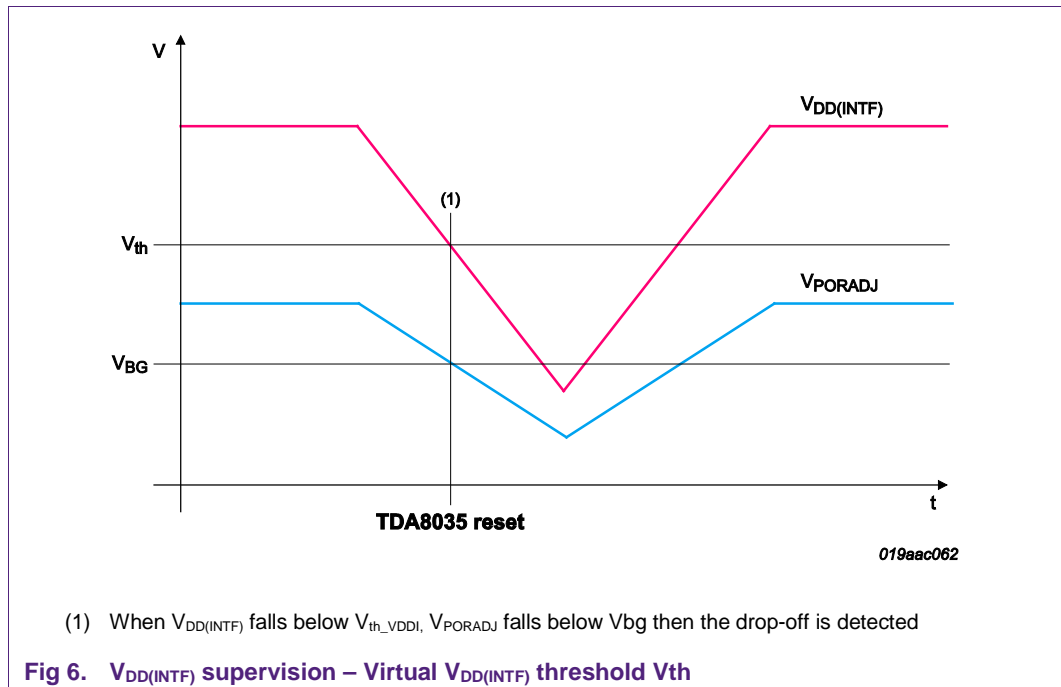

(1) When $V_{DD(INTF)}$ falls below V_{th_VDDI} , V_{PORADJ} falls below V_{bg} then the drop-off is detected

Fig 6. $V_{DD(INTF)}$ supervision – Virtual $V_{DD(INTF)}$ threshold V_{th}

The resistor bridge is needed only in the case a specific threshold on $V_{DD(INTF)}$ must be chosen for the application, but in the general case, $V_{DD(INTF)}$ can be input directly on PORADJ.

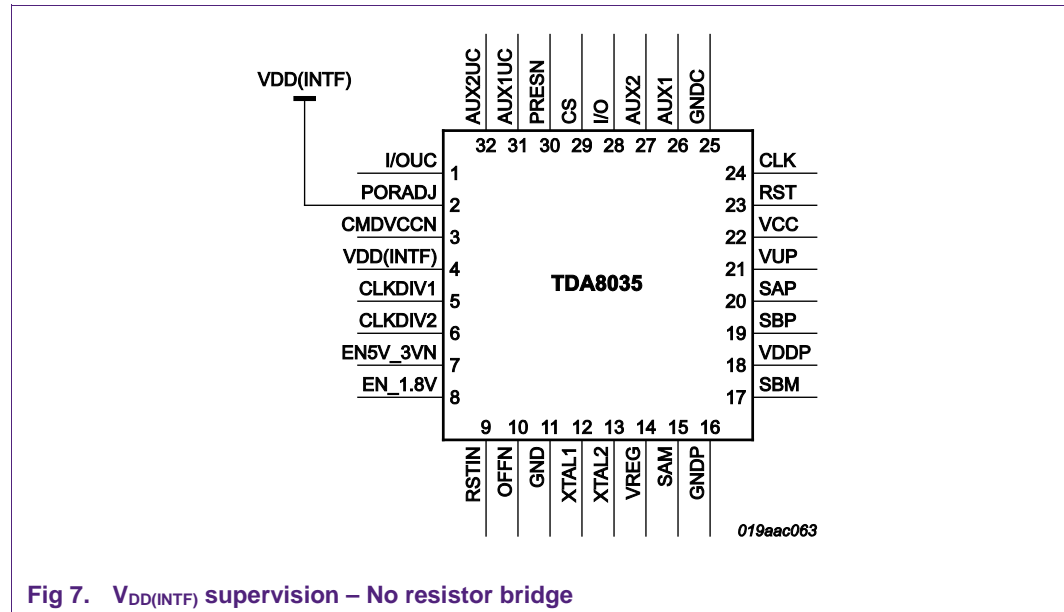

Fig 7. $V_{DD(INTF)}$ supervision – No resistor bridge

This is a particular case of the previous description with $R1 = 0\Omega$ and $R2 = \infty$.

Here $V_{th} = V_{bg} \cdot (1 + R1/R2) = V_{bg}$.

2.2.3 Summary

The following table gives the different threshold values for each supply input pin.

Table 2. Supply supervisor - Typical threshold values

	V_{REG}	V_{DDP} ($V_{CC} = 5V$)	$V_{DD(INTF)}$ (No PORADJ bridge)	$V_{DD(INTF)}$ (PORADJ bridge used)
Typ. V_{th}	1.45V	2.25V	0.86V	$0.86 \times (1 + R1/R2)$
Typ. V_{hys}	100mV	100mV	60mV	60mV

2.3 DC/DC Converter

The TDA8035 embeds a DC/DC converter that allows converting a voltage level as low as 2.7 V to an output on the card side up to 5 V.

This block is supplied through VDDP, and its reference ground is GNDP.

2.3.1 Schematics

This DC/DC converter works with a capacitor step-up mechanism, and uses 3 capacitors on SAM-SAP, SBM-SBP and VUP

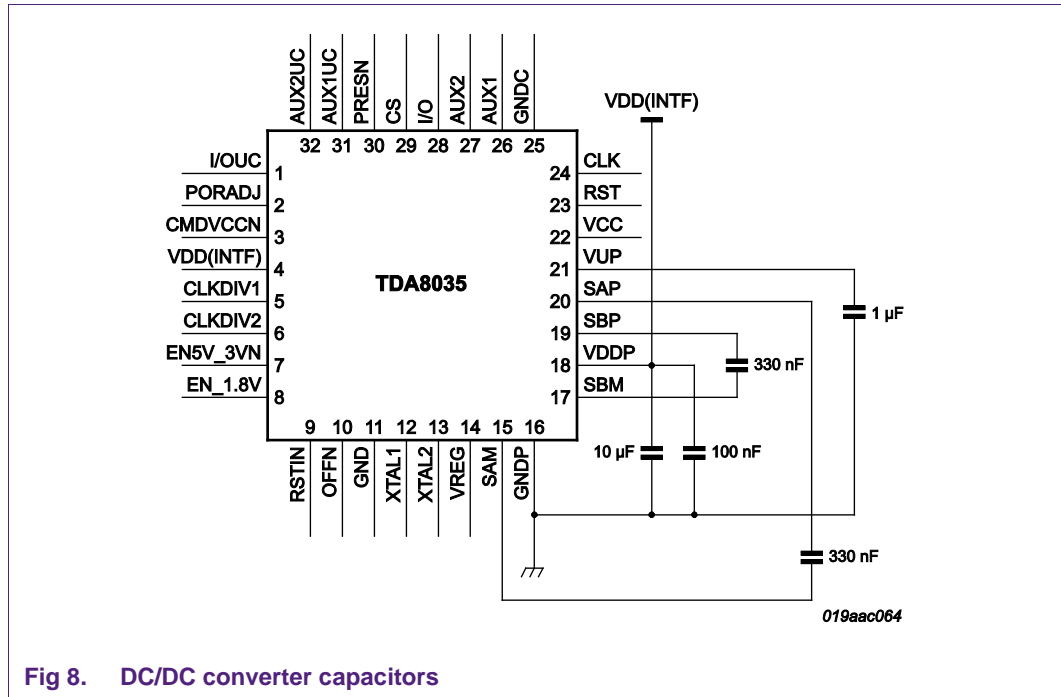

Fig 8. DC/DC converter capacitors

The DC/DC converter operates as a charge pump using capacitors on SAx pins, SBx pins and Vup. With these 5 pins the converter can operate as a voltage follower, doubler, or even tripler. This allows to use a VDDP down to 2.7 V, and then allows to use the same level voltage for VDDP and VDD(INTF).

2.3.2 Layout

The DC/DC converter components layout must be implemented respecting the following guidelines:

- The 10 μF capacitor on VDDP has to be routed close to the VDDP pin and with a very short and low resistive connection to the GNDP pin.
- The 1 μF capacitor on Vup has to be placed close to Vup and with a very short and low resistive connection to the GNDP pin.
- The 100 nF on VDDP must be placed close to the VDDP pin.
- The capacitors on SAP/SAM and SBP/SBM must be placed close to their pins.

2.4 Low consumption

The TDA8035 has two different low consumption states where the current consumption differs:

- Shutdown mode, when no card is active and the TDA8035 is in stand by
- Deep shutdown mode, when the TDA8035 is forced in a sleeping state.

2.4.1 Shutdown mode

The shutdown mode is the default mode when the card is not active (CMDVCCN HIGH). The max consumption in this mode is 500 μA .

Due to this mode, the activation timing changes a bit compared to the TDA8024. Refer to the "Activation" chapter to see the exact difference induced by this mode.

In this mode the supervisors are active, card presence detection is available.

2.4.2 Deep shutdown mode

The deep shutdown mode is a very low consumption mode (2 μA max). This mode can be entered when the card is not active (CMDVCCN HIGH) by tying EN5V3VN and EN1V8N to the LOW state.

In this mode, the supervisors are turned off, but the presence detection is still available: the OFFN pin follows the status of the presence (PRESN inverted).

This mode can for example be used when no card is present. In this case, the TDA8035 cannot be used and the host can only wait for a card insertion before activating it. The following figure gives a usage example with 5V smart cards:

Note: in the case that in the application the clock is supplied by the host controller, the clock input shall be stopped prior to entering deep shutdown mode.

In case of external crystal, it will be automatically stopped by the TDA8035.

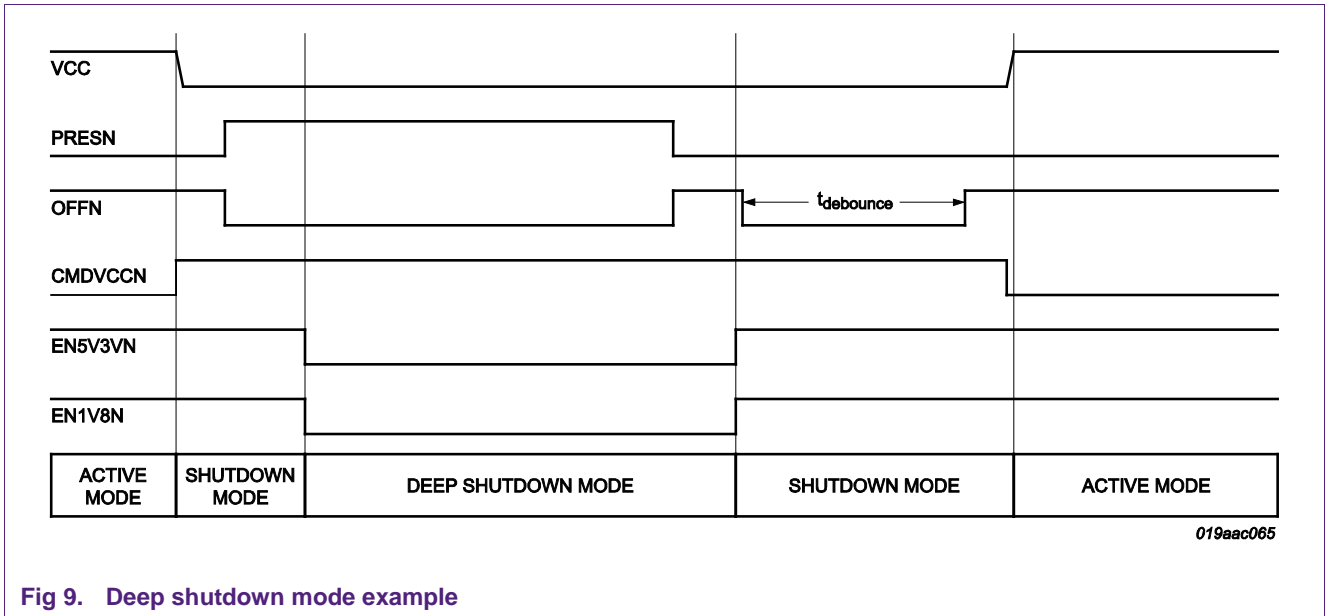

Fig 9. Deep shutdown mode example

In order to use the two configuration pins EN3V5VN and EN1V8N as card voltage selection mode, refer to the chapter 6.1 Card voltage.

3. Input Clock

3.1 Clock selection

There are two possibilities to provide the clock to the TDA8035: using a crystal or applying an external clock provided by the microcontroller.

Any value of crystal can be used from 2 MHz to 27 MHz.

The XTAL pins are referenced to $V_{DD(INTF)}$. In the case of a crystal, the high level of the clock is equal to $V_{DD(INTF)}$, and in case of an input clock, it must be referenced to $V_{DD(INTF)}$.

The type of clock is detected automatically by the TDA8035. Hence there is no specific configuration.

The clock is not mandatory outside of the card session. This means that if a crystal is used, it will only toggle when CMDVCCN is low. There is no activity on XTAL1 when CMDVCCN is HIGH.

If an external clock signal is applied to XTAL1, it is mandatory to start it before CMDVCCN is LOW, but it is not necessary to apply it when the card must not be activated.

The following figures represent the two configurations and the way they are used.

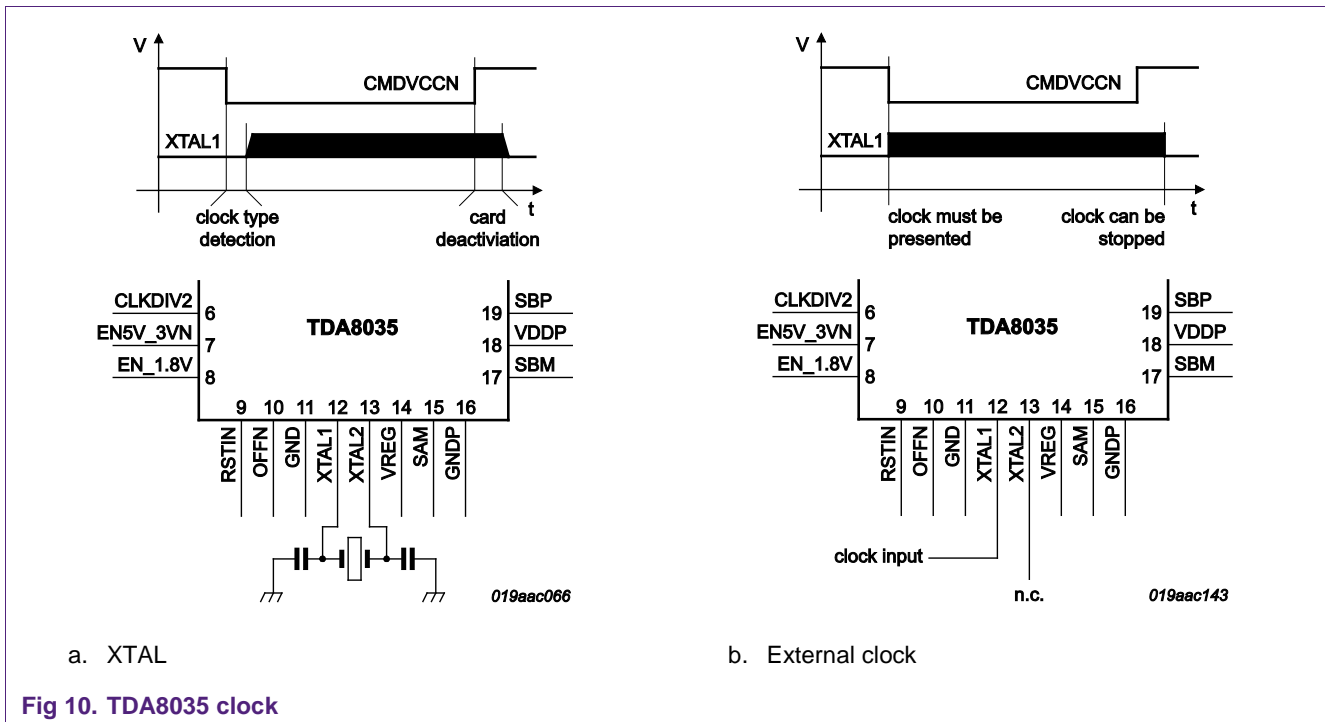

Fig 10. TDA8035 clock

3.2 Duty cycle

On the card side, the duty cycle of the clock line must be in the range 45 % to 55 % to be compliant with most of the standards.

This duty cycle is guaranteed by the TDA8035 for any clock generated by the TDA with a division by 2, 4 or 8.

Therefore, whatever the input clock frequency, duty cycle, voltage levels on the host side, as long as they respect the input specification, the card CLK duty cycle will be in the range.

But if the input clock is not divided to generate the card CLK, the duty cycle will directly depend on the input clock parameters.

The most probable case is having an external input clock which is not centered on $V_{DD(INTF)}/2$. In this case, due to the V_{IL} and V_{IH} parameters, the output clock to the card may not have a correct duty cycle, as shown on the following oscilloscope picture.

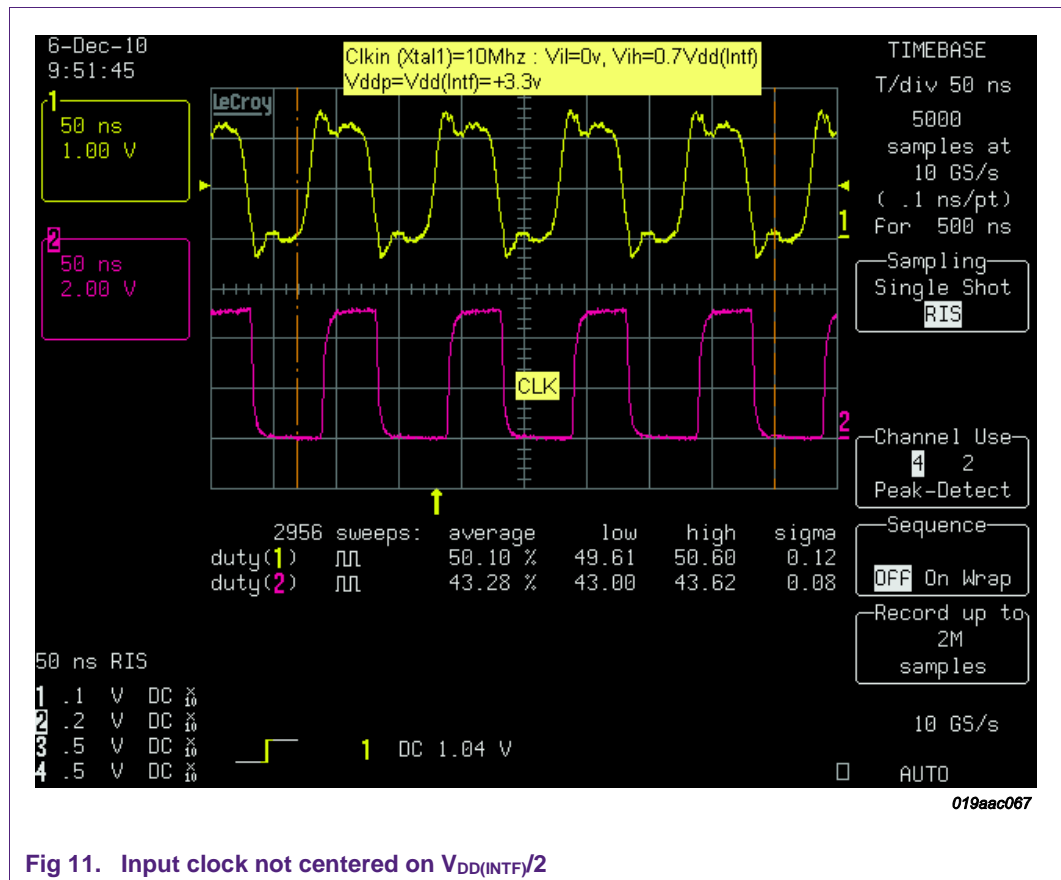
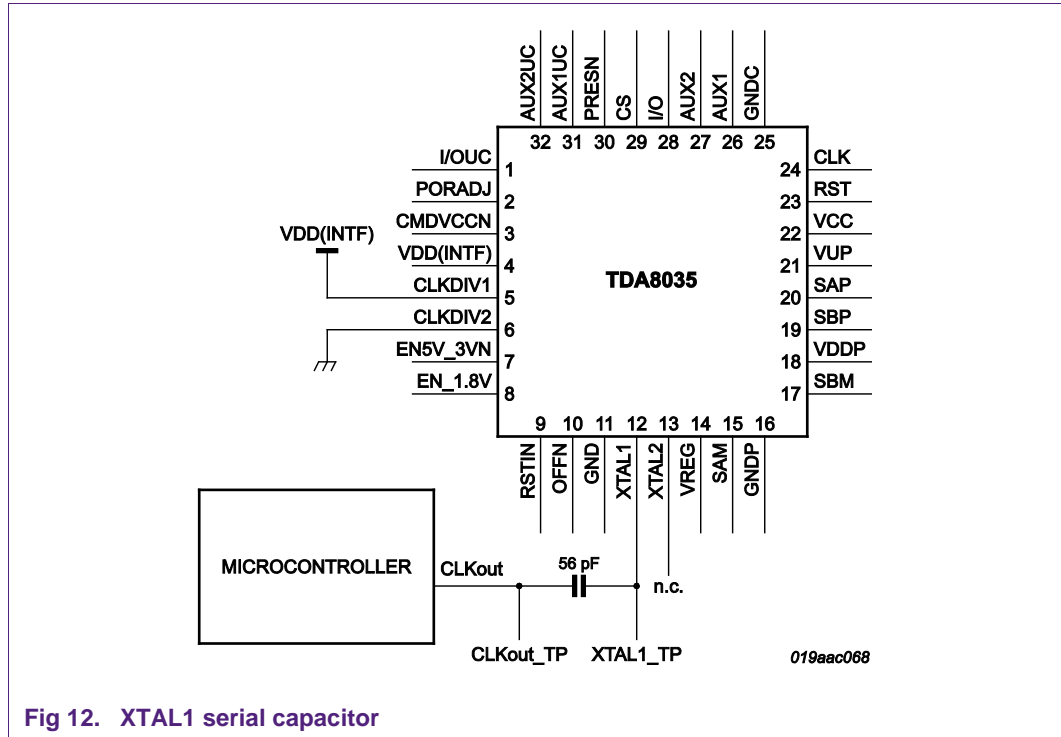

Fig 11. Input clock not centered on $V_{DD(INTF)}/2$

This test shows that even though the input clock has a 50% duty cycle, as it is not centered on $V_{DD(INTF)}/2$, the duty cycle of generated clock on CLK pin is not equal to 50%.

To avoid this issue, it is recommended to center the input clock by adding a serial 56 pF capacitor in serial in the XTAL1 line, as described on the following drawing.



Thanks to this serial capacitor, the clock signal DC level is cancelled, and the signal is now centered on $V_{DD(INTF)}/2$.

The result is that the CLK line duty cycle is now equal to the input duty cycle.

The result is shown in the next figure, showing the different signals:

- Yellow – Voltage Level on XTAL1_TP
- Blue – Voltage Level on CLKOut_TP
- Pink – Output on CLK (pin #24)

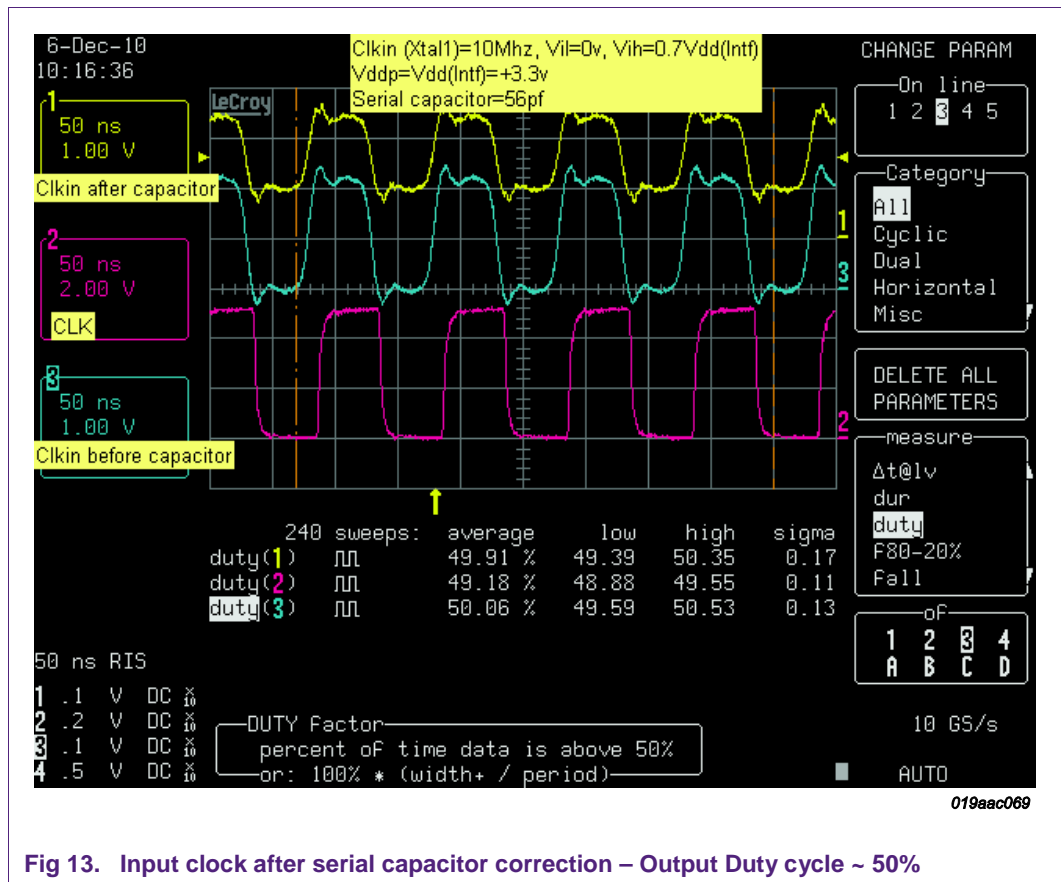

The duty cycle is now around 50% on the CLK line.

4. Chip select

The TDA8035 implements a functionality that allows to cascade several devices using the same connection pins. The following signals can be multiplexed:

- CMDVCCN
- RSTIN
- CLKDIV1
- CLKDIV2
- EN5V/3VN
- EN1V8N
- IOUC
- AUX1UC
- AUX2UC
- OFFN

4.1 Active device

To drive a TDA8035, its corresponding CS pin must be tied to high level. Then all the configuration pins behaves as expected.

If the CS pin is pulled to low, then all the pins are high impedance and the TDA8035 keeps internally its last configuration.

The following figure shows the behavior, when the TDA8035 is fixed in its state when CS is low. Whatever the value of any configuration pin, the behavior is always the same. The figure shows this behavior with CMDVCCN. The value on CMDVCCN only has an action on the chip when CS is high, or becomes high.

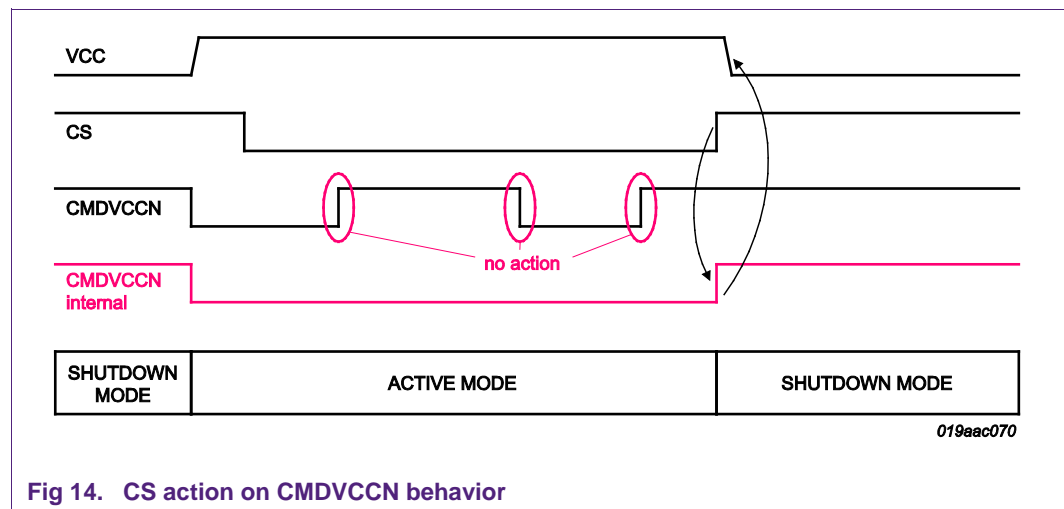

The signal CMDVCCN Internal represents the value that is seen by the TDA8035: the value is latched as soon as CS goes low, and can only change after CS goes back high. In this case, when CS rises, CMDVCCN internal become high, which causes the deactivation.

The behavior of OFFN is affected in the same way by CS. OFFN from any unactive device will always be kept to high level. Then the host must regularly check each device to know its state.

The following figure gives an example with a card removal when the device is not active:

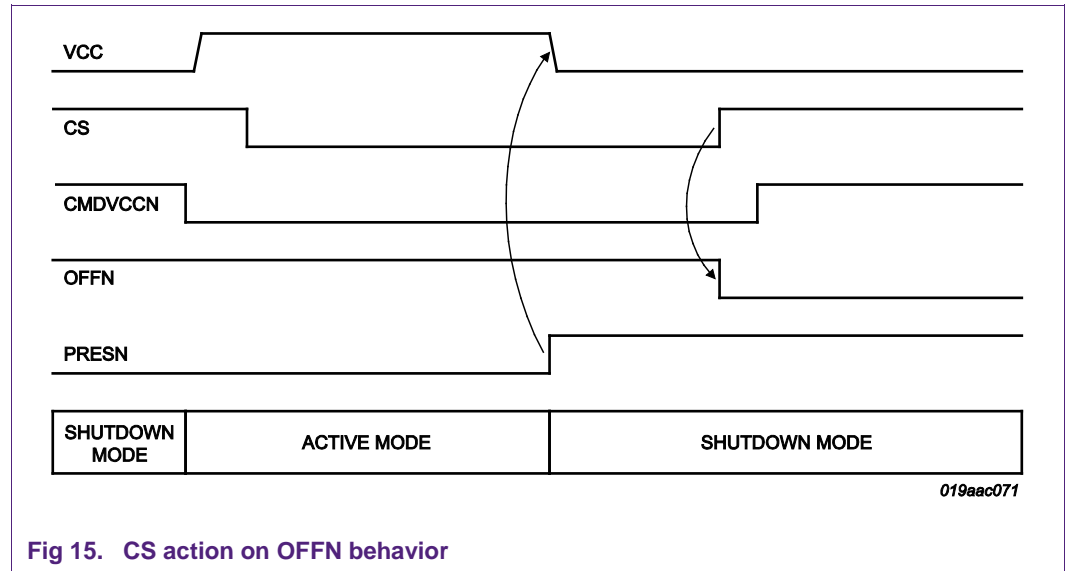

Fig 15. CS action on OFFN behavior

This shows that when the card is removed (or by extension when any fault is detected), the TDA automatically deactivate the card, in order to protect it.

But the host is not warned if the CS pin is low. It will only know that the fault occurred after it has pulled the CS pin high.

4.2 Schematics

The following schematics give an example on how to connect 2 TDA8035 to a host.

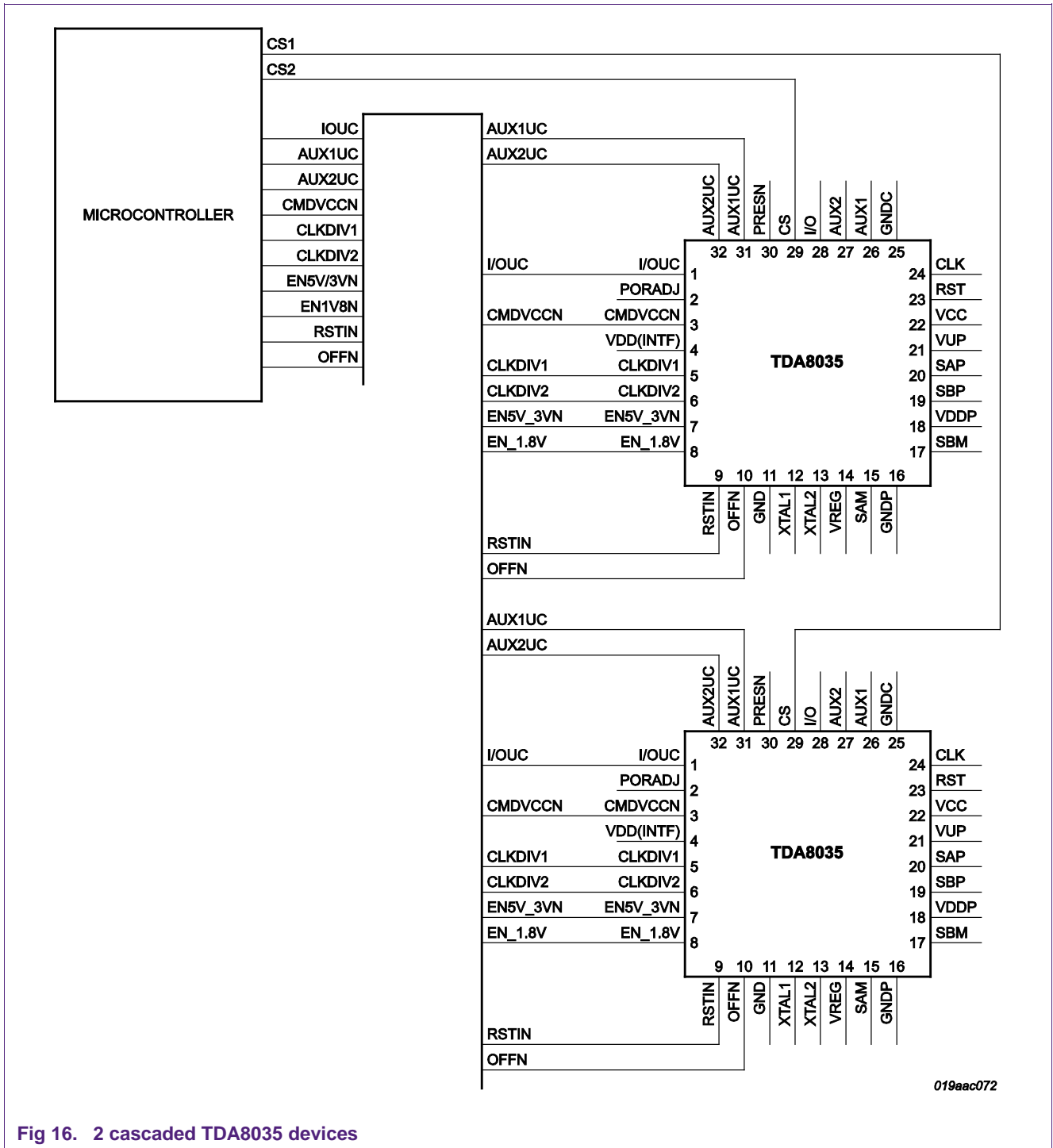

Fig 16. 2 cascaded TDA8035 devices

4.3 Device switch

Using the previous design, some precautions must be taken when switching from one device to another:

Only one CSx signal must be active at the same time

The configuration signals must be saved before clearing the CSx pin, and restored before rising the CSx pin.

The following picture shows the sequence that must be followed to activate smart card from device 1, then activate smart card from device 2, and finally send APDU to device 1.

Only CMDVCCN behavior is shown here, but all input signals must be handled in the same way (save and restore).

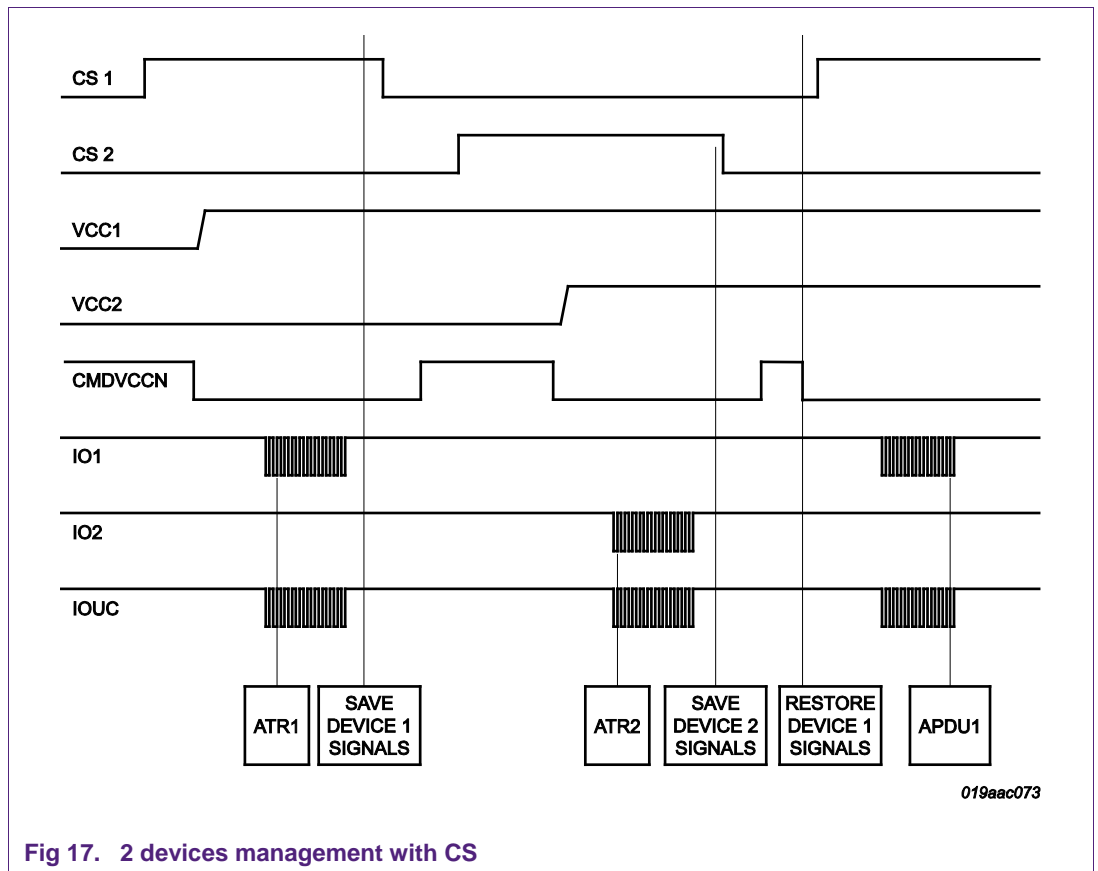

Fig 17. 2 devices management with CS

5. Card connector

5.1 Presence pin

One input pin is available to detect the card presence: PRESN.

This pin is active LOW and embeds an internal resistor to GND. Therefore, when the pin is left open, the card is assumed to be present.

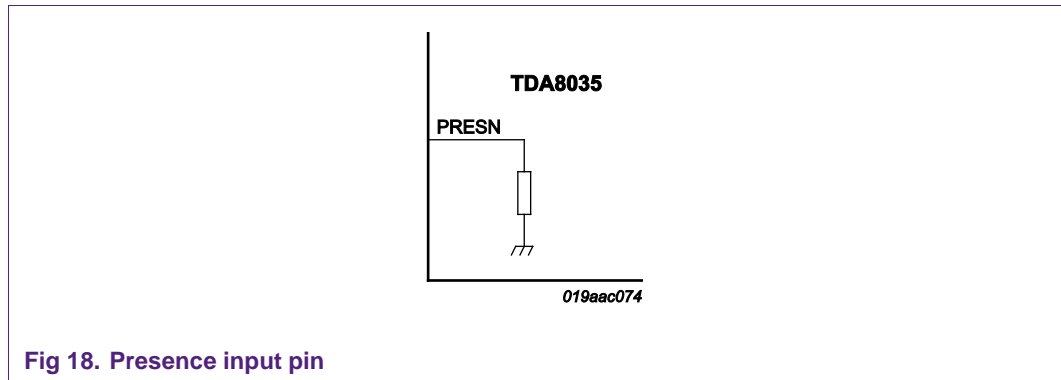

Fig 18. Presence input pin

The way to connect the switch of a smart card connector depends on its gender (normally open or normally closed).

5.1.1 Normally closed presence switch

The TDA8035 is planned to be used with this type of card connector without any external component. The connection of this card connector presence switch is shown in the next figure:

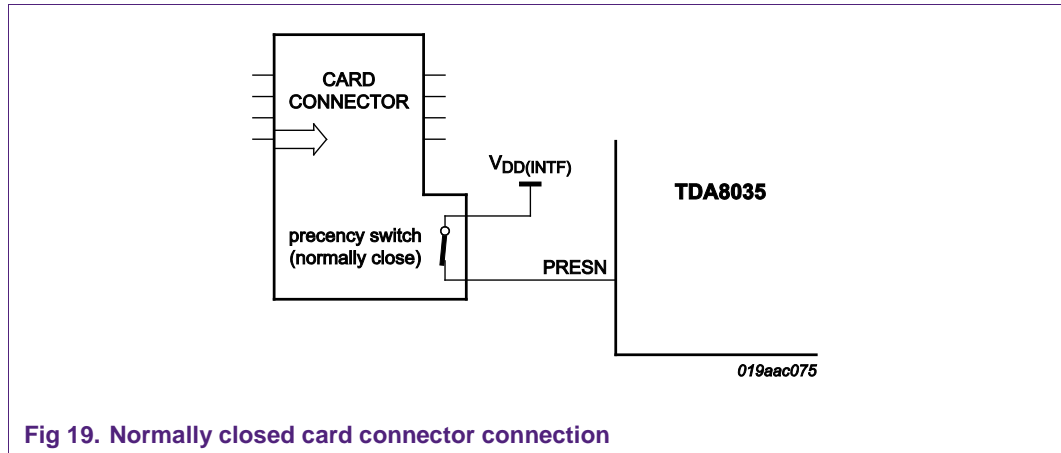

Fig 19. Normally closed card connector connection

When the card is not inserted, the switch is closed, and the PRESN pin is not active and the card is assumed to be absent.

When the card is inserted, the switch is opened and the PRESN pin is driven to low by its internal resistor connected to the ground. The pin is active and the card is seen as present.

5.1.2 Normally open presence switch

5.1.2.1 Schematics

To use this type of card connector, an external resistor is mandatory, and the schematics must be used as shown hereafter:

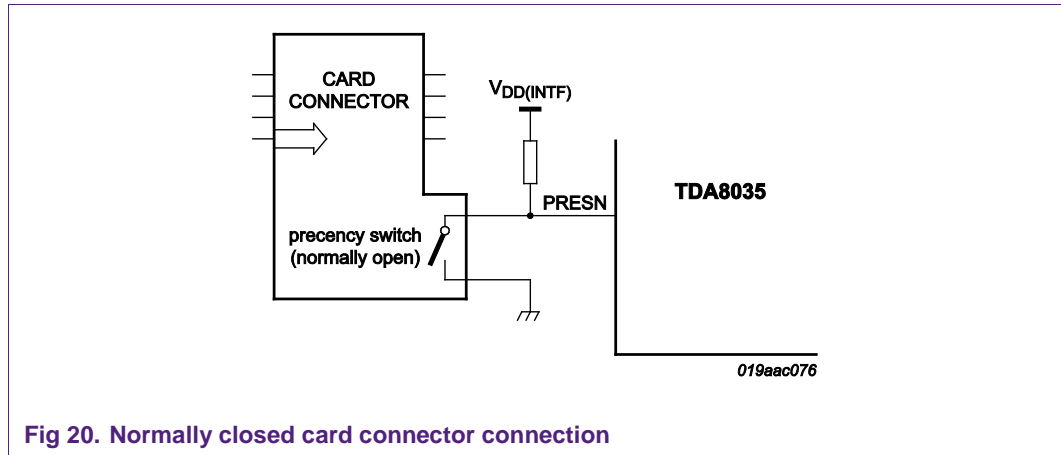

Fig 20. Normally closed card connector connection

When the card is not inserted, the switch is open and PRESN is pulled-up to HIGH level. The pin is not active so the card is seen as absent.

When the card is inserted, the switch is closed. Then the PRESN pin is directly connected to ground. PRESN is then active and the card is seen as present.

5.1.2.2 Pull-up resistor calculation

The PRESN is internally connected to GND through a pull-down resistor.

Depending on the PRESN level, the pull-down resistor can have different value:

- When PRESN is high (not active), the resistor value is 1MΩ (to reduce current consumption)
- When PRESN is low (active), the resistor value is 30kΩ

To choose the pull-up resistor, the 30kΩ value must be taken into account. Indeed, the goal is to pull the PRESN line to VDD(INTF) when the card is removed and the switch opened.

The 30kΩ pull-down has a 20% precision, then the minimum value can be 24kΩ.

If R_{ext} is the external pull-up and R_{int} the internal pull-down, then the PRESN voltage level is:

$$V_{PRESN} = V_{DD(INTF)} \times R_{int} / (R_{int} + R_{ext})$$

To be detected as high, V_{PRESN} must be greater than V_{IH}. Then the constraint on R_{ext} is:

$$R_{ext} > R_{int} \times (V_{DD(INTF)} - V_{IH}) / V_{IH}$$

For instance, if V_{DD(INTF)} = 3.3V, then V_{IH} = 0.7*3.3V = 2.31V

As R_{int} min is 24kΩ, R_{ext} max = 10.28 kΩ.

A maximum value of 10kΩ must be used in this case.

5.1.3 Debouncing

With some card connectors, depending on the mechanical characteristics of the switch, bouncing may be seen on the PRESN pin when a card is inserted or extracted. This bouncing is managed by the TDA8035 which does not transfer exactly the PRESN state to the OFFN pin.

When the card is inserted, the TDA8035 waits for the PRESN pin to be stable for several milliseconds before assuming that the card is inserted. When the card is extracted, the chip acts as soon as the presence is not active. This behavior is summarized in Fig 21:

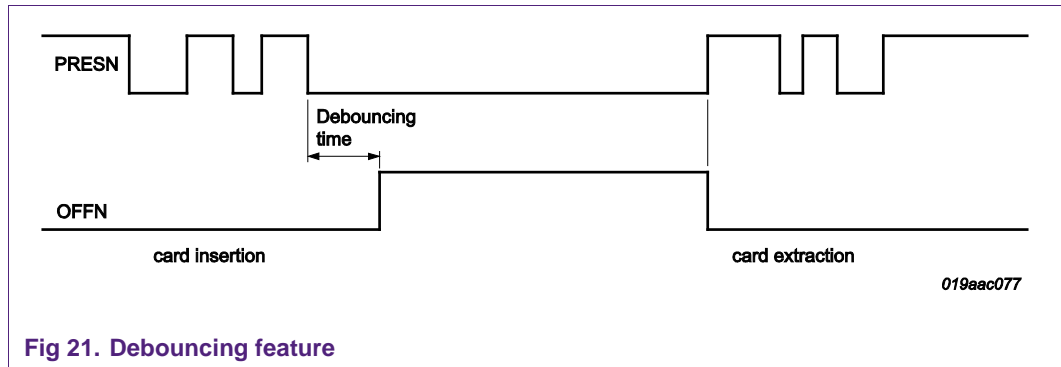

Fig 21. Debouncing feature

5.2 Schematics

To connect the smart card connector to the TDA, only two capacitors are mandatory as external components. The schematic reference is given in Fig 22.

The C1 capacitor must be placed near the TDA8035 and C2 must be connected close to the card connector.

The advised values for C1 and C2 are respectively 220 nF and 220 nF. These values are mandatory to have a ripple on VCC in the specified limits.

Pins C4 and C8 of the card connector (connected to pins AUX1 and AUX2) are optional. They can be left unconnected unless some specific operation using these pins is required.

It is not advised to leave pin VPP (C6) unconnected. It can be connected directly to VCC or GND in accordance with latest ISO 7816 standards. Connecting it to VCC allows it to be compliant with older cards which might not support VPP connected to the Ground.

For more flexibility, the design should include a 0 ohm serial resistor between VPP and VCC. Then the application can be easily adapted if needed.

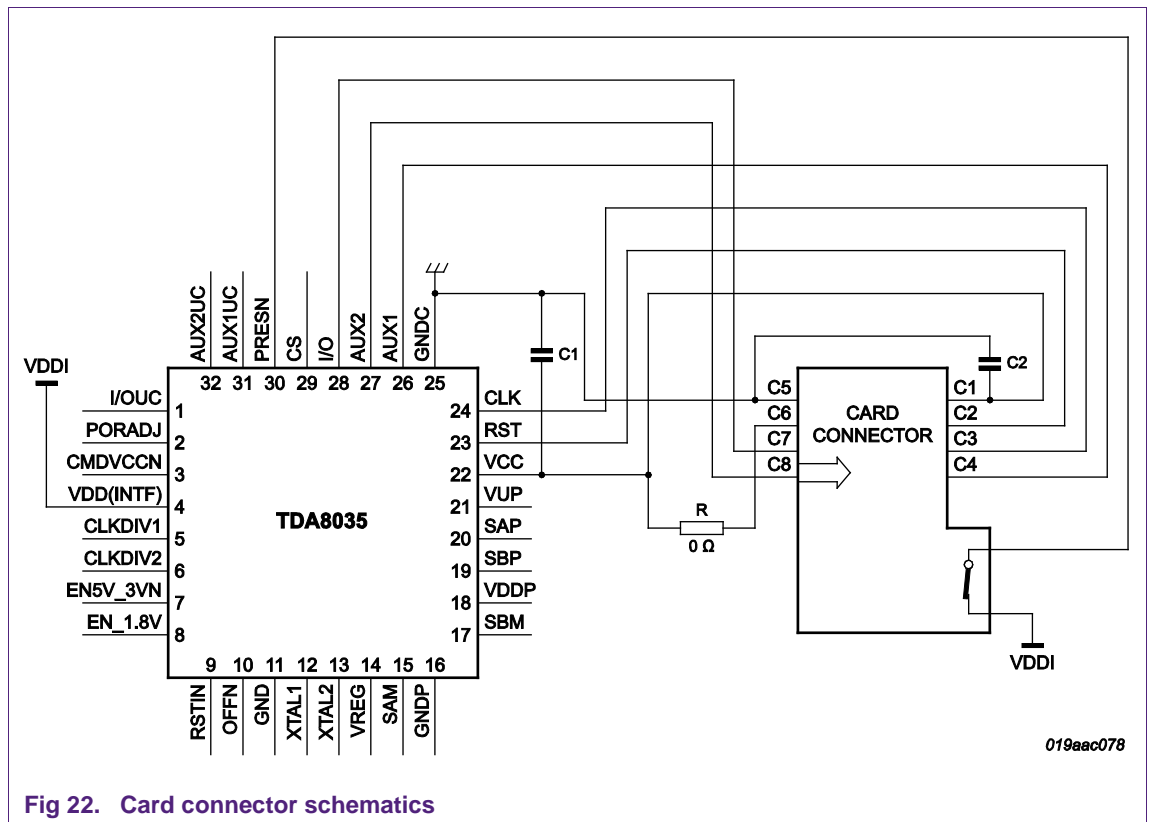

Fig 22. Card connector schematics

6. Card configuration

The chip can be configured dynamically to operate with the connected card. Two parameters can be controlled: the voltage level and the frequency of the clock signal to the card.

6.1 Card voltage

The voltage level is configured with the following pins:

- EN_1.8VN
- EN_5V/3VN

These pins must be connected to an output of the host. This connection is recommended even for applications using a dedicated 5V card, in order to be easily compliant with the next generation cards.

The voltage level has to be configured before activation. The application **MUST NOT** change the value of these pins when the card is activated.

To change the voltage level of the card, the host must deactivate the card, change the voltage level value and then re-activate the card.

These pins are also used for the deep shutdown mode.

The following table gives the action of each combination of these inputs.

Table 3. Select voltage pin behavior

Command	EN5V3VN	EN1V8N
Deep Shutdown	0	0
VCC = 1,8V	1	0
VCC = 3V	0	1
VCC = 5V	1	1

6.2 Card clock

6.2.1 Frequency selection

Two signals are used to select the card clock:

- CLKDIV1
- CLKDIV2

These signals must be connected to the host and determine the division ratio of the input frequency in the clock which is sent to the card when activated.

The following table describes the frequency corresponding to CLKDIV1/2 values. f_{XTAL} is the frequency applied on XTAL1 (crystal or external source).

Table 4. TDA8035 - Clock division selection

CLKDIV1	CLKDIV2	CLK
0	0	$f_{XTAL}/8$
0	1	$f_{XTAL}/4$
1	1	$f_{XTAL}/2$
1	0	f_{XTAL}

6.2.2 Frequency switch

6.2.2.1 General behavior

CLKDIV1 and CLKDIV2 can be changed freely when the card is not active. The values will be adopted on activation.

When the card is active, the frequency applied to the card can be switched by changing CLKDIV1 and CLKDIV2 as shown in the following figure:

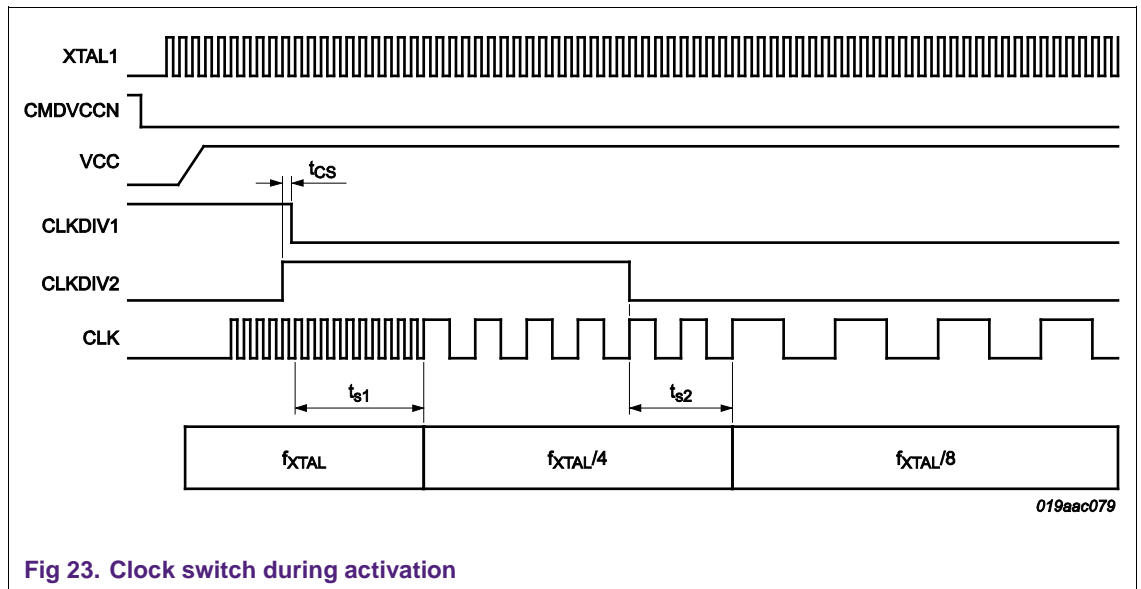

Fig 23. Clock switch during activation

The clock starts with the value specified at activation. Then the clock frequency switch occurs after a maximum of 10 XTAL1 periods after a change is seen on CLKDIV1/2 ($t_s < t_{smax} = 10 \text{ clock cycles}$).

6.2.2.2 Simultaneous change on CLKDIV1 and CLKDIV2

When both CLKDIV1 and CLKDIV2 have to be changed simultaneously, a maximum delay of 1 XTAL1 period (t_{cs}) is required between the two edges.

If this timing is not respected, an undesired frequency can be observed during the frequency switchover as shown in the next figure: a switch from f_{XTAL} to $f_{XTAL}/4$ is performed, but a frequency of $f_{XTAL}/2$ is seen during the switchover.

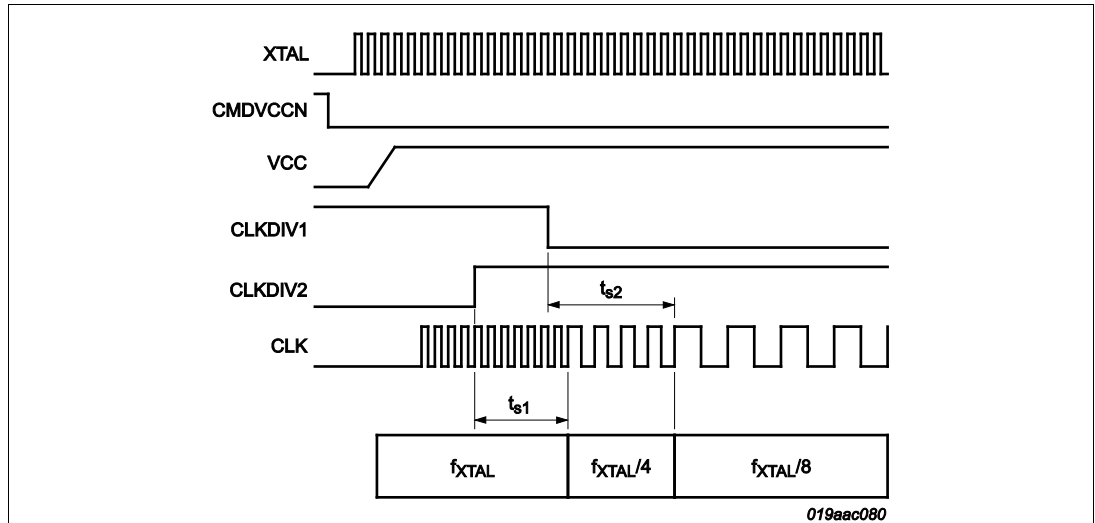

Fig 24. Unwanted frequency during the switch

7. Card Activation / Deactivation

7.1 Difference TDA8024 – TDA8035

7.1.1 Activation timing

The electrical interface between the host and the TDA is based on GPIOs and is exactly the same for TDA8035 as for TDA8024, as soon as the CS pin of the TDA8035 is High.

In the card management, the only difference between the TDA8024 and TDA8035 is the delay between CMDVCCN Low and VCC High.

This time is very low for the TDA8024 while it is equal to 3.42 ms in the TDA8035. (See next chapter)

7.1.2 Software

When the TDA8035 is implemented in a design, the software already developed for the TDA8024 can be reused, with a little modification in one case:

If, for the TDA8024, the delay between VCC High and RST High had been set to a low value (below 3.5 ms), this delay must be changed to a highest value, as described in the next chapter.

If the delay is greater than 3.5 ms, then the same code can be reused without any change.

7.1.3 Test Mode / IOUC

Due to the test mode (see chapter **Error! Reference source not found.**), it is mandatory for the host to keep IOUC high when pulling CMDVCCN to low.

The TDA8024 does not use this test mode. Then the activation always works regardless of the state of IOUC.

7.2 Activation

7.2.1 Timings

To activate the card, two signals are controlled by the host: CMDVCCN and RSTIN. The first signal sets the card power supply, the second controls the reset pin of the card. In the simplest mode, two actions are required from the host to activate the card: reset CMDVCCN and then set RSTIN. The activation sequence is shown in Fig 25.

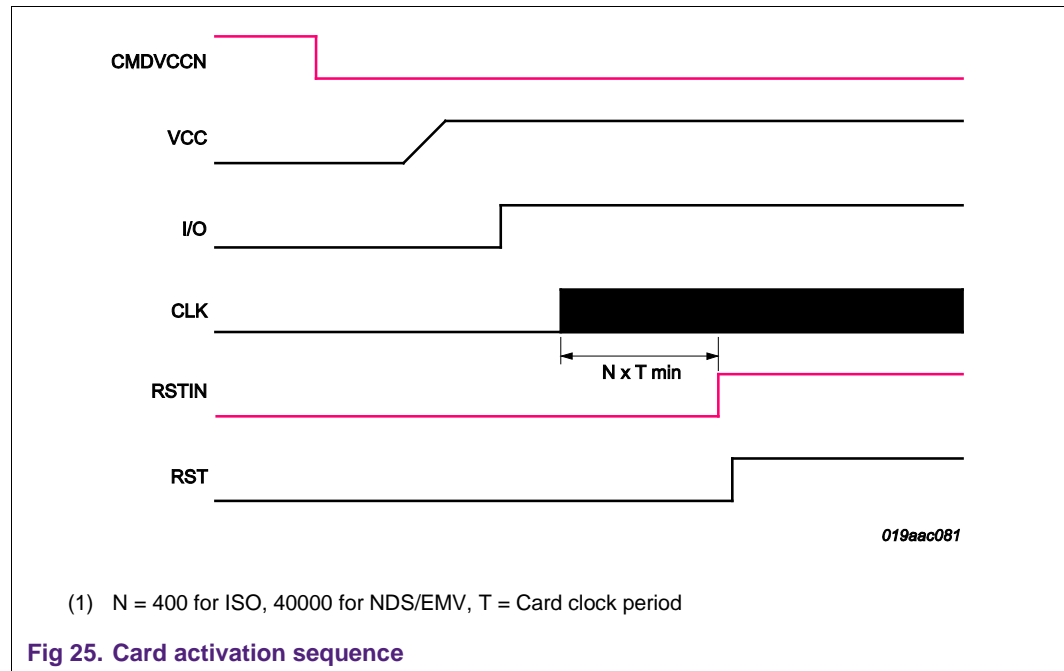

The input clock must be OK for this sequence to occur. If the clock is supplied externally (no crystal), the clock must be present and stable before the falling edge of CMDVCCN.

The only constraint on the host is due to the standard specifications:

For the ISO 7816, the host must wait at least 400 clock cycles after the clock is active, before asserting RST.

In NDS and EMV specifications, the delay must be 40000 clock cycles

However in this mode, the host has no way of knowing when the clock starts. So it is not possible to count precisely the number of cycles.

To be sure that the right number of clock cycles are respected, the host must know the timing between CMDVCCN fall, VCC rise and CLK start.

These timings are given in the following figure

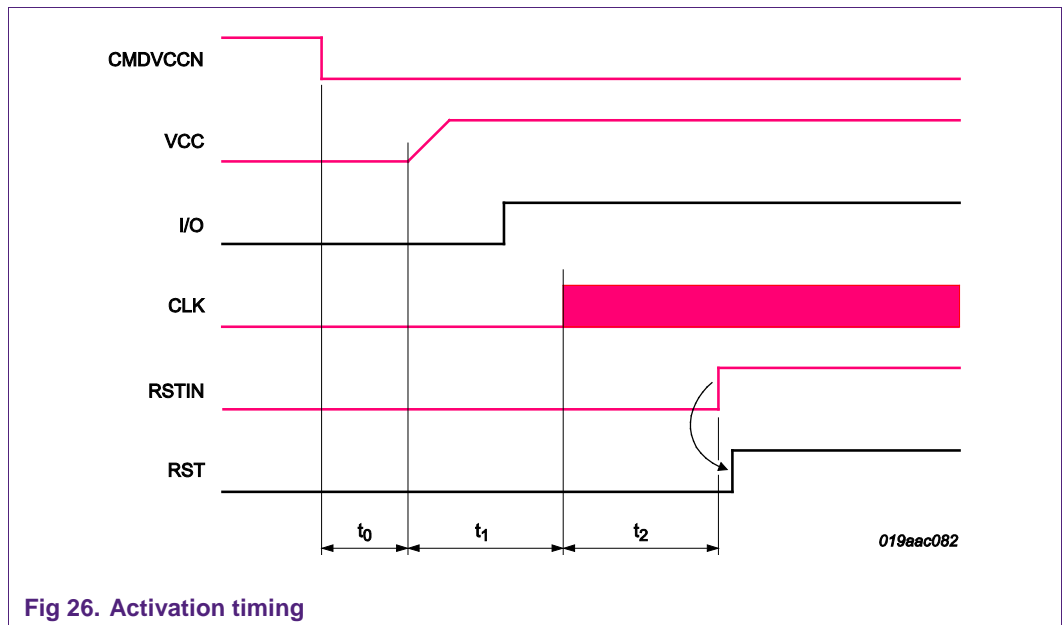

Fig 26. Activation timing

During t_0 , the TDA8035 checks for the XTAL1 pin to detect if a crystal is present or if the clock is supplied from the microcontroller, and then waits for the crystal to start.

This time is fixed, even if there is no crystal, and its maximum value is 3.1 ms.

t_1 is the time between the beginning of the activation and the start of the clock on the smart card side. This time depends on the internal oscillator frequency and lasts at maximum 320 μ s.

The host must then assume that the smart card clock doesn't start before 3.42 ms after CMDVCCN has been set to LOW.

To set RSTIN, the host must wait at least 400 (ISO) or 40000 (NDS/EMV) clock cycles after the start of CLK. Therefore t_2 depends on the input clock and on the division applied to supply the clock to the smart card and must be managed by the host.

The time between CMDVCCN low and RSTIN high, must respect this condition:

$$t_0+t_1+t_2 > 3.42\text{ms} + 400/f_{\text{CLK}} \text{ OR}$$

$$t_0+t_1+t_2 > 3.42\text{ms} + 40000/f_{\text{CLK}}$$

7.2.2 IOUC / Test Mode

The TDA8035 implements a test mode for production test purpose. This mode is not intended to be used in application.

This mode is entered by keeping IOUC Low when pulling CmdVCCN to low.

To avoid entering this test mode when activating the card, it is mandatory that IOUC is forced to high when CMDVCCN is pulled to low.

If IOUC is low while activating, the test mode is immediately entered.

It is possible to know that the test mode is entered as OFFN will fall a few nanoseconds after CMDVCCN has been pulled to low. In case of activation error in normal mode (eg shortcut on VCC or too much load on the DC/DC Converter), OFFN should never fall to low until a few milliseconds.

7.3 Deactivation

The deactivation is managed entirely by the TDA8035 sequencer. Deactivation occurs when one of the following events happens:

- Rising edge of CMDVCCN (normal host deactivation)
- A fault is detected:
 - Card removal
 - Overheating
 - Short-circuit or high current on VCC
 - $V_{DD(INTF)}$, VDD or VDDP drop

The deactivation sequence is automatic and fully compliant with the standard. For more details on the activation or deactivation sequence and their timings, refer to the TDA8035 data sheet and ISO 7816-3 standard.

8. Card operation

8.1 I/O, Aux1, Aux2

The TDA8035 acts as a simple transceiver incorporating a voltage level shifting adaptation for these signals, once the card is activated.

As there is no other conversion, the host must manage entirely the protocol defined by ISO 7816 (Baudrate, timing, frame...).

The TDA8035 only limits the current on the pins. There is a limitation of 15 mA in both directions.

- I/O is linked to I/OUC,
- AUX1 to AUX1UC, and
- AUX2 to AUX2UC.

I/OUC must be connected directly to an I/O of the host. AUX1UC and AUX2UC can as well be connected to the host or left open if C4 and C8 pin are not used on the card.

8.2 Warm reset

The host can operate a warm reset with the TDA8035: as the RST card pin is the copy of the RSTIN pin, the host just needs to apply a falling edge on RSTIN, followed by a rising edge, and the card shall send its ATR again.

9. OFFN Behavior

9.1 Fault detection

The TDA8035 supervises several parameters and warns the host when a problem occurs. The OFFN pin is used to manage this communication with the host. The table below gives the state of the chip in accordance with CMDVCCN and OFFN values.

In this table it is assumed that CS pin is HIGH.

Table 5. Chip state regarding CMDVCCN and OFFN

CMDVCCN	OFFN	State	Comment
HIGH	HIGH	Card is present and not active	
HIGH	LOW	Card is absent	
LOW	HIGH	Card is active and no fault has been detected	This is the state of all card sessions
LOW	LOW	A fault has been detected (card has been deactivated)	The cause of the deactivation is not yet known.
Rising edge	Stays LOW	The fault detected was the card removal	Setting CMDVCCN allows checking if the deactivation is due to card removal. In this case the OFFN pin will stay low after CMDVCCN is high.
Rising edge	Rising edge	The fault detected was not a card removal (card is still present)	If OFFN follows CMDVCCN, the fault is due to a supply voltage drop, a VCC over-current detection or overheating.

9.2 Deep shutdown specific behavior

In shutdown or deep shutdown mode, OFFN is only informing about the card presence. Nothing else is checked.

But one specific behavior on OFFN may occur in case deep shutdown mode is used:

In one case, when exiting the deep shutdown mode, a short high level can be seen on OFFN.

This case is the following:

- Enter the deep shutdown mode with card inserted → OFFN is HIGH
- Extract the card during deep shutdown mode → OFFN falls
- Exit shutdown mode → OFFN goes HIGH, stays HIGH for ~10 μs, and goes LOW.

This behavior is a normal behavior as the digital part is resetting at this time, but it can cause unexpected behavior on the CPU in case the interrupt service routine is not correctly handling this pin.

This behavior is explained by the next drawing.

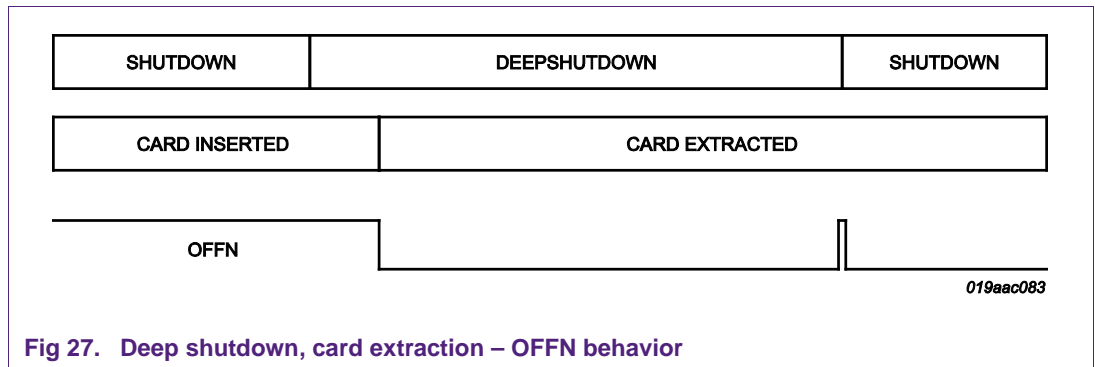

Fig 27. Deep shutdown, card extraction – OFFN behavior

10. Electrical design recommendations

10.1 Decoupling

To ensure proper behavior of the TDA8035, some external components have to be used. All supply pins must be protected against noise.

VCC pin (card contact) needs to be connected to two capacitors: twice 220 nF as described in chapter 5.2: one near the TDA8035 chip and one near the card connector. These capacitors type must be low ESR.

$V_{DD(INTF)}$ and VREG must be protected by 100nF.

VDDP must be protected by two capacitors: one 100 nF to protect particularly against high frequency noise and one 10 μ F to absorb slower variations.

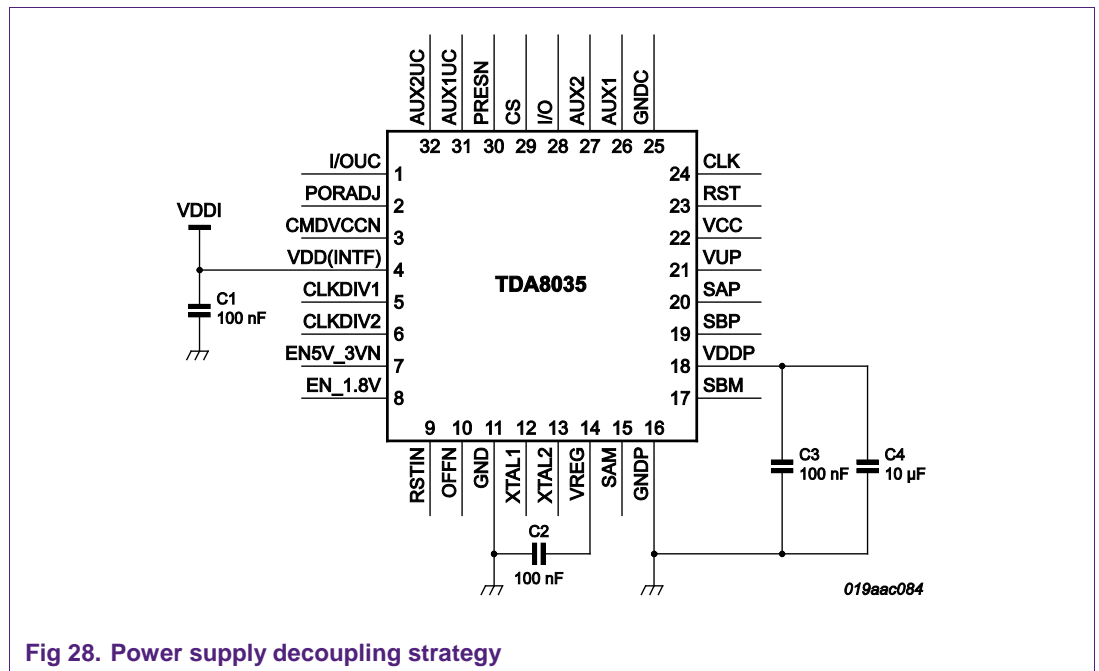

Fig 28. Power supply decoupling strategy

10.2 Layout

For noise reduction optimization, the layout of the design must adhere to the following guidelines.

10.2.1 Decoupling capacitors

Capacitors are mandatory to protect the supply pins as well as the VCC pin (TDA8035 pin and Card connector pin).

Place decoupling capacitors as close as possible to the pin that they protect.

This means that the capacitor must be physically soldered near the chip or the card connector pin, but also with a short and good connection (low resistance) between the protected pin and its capacitor.

The connection between the capacitor pin and the ground must be short low resistive as well.

10.2.2 DC/DC capacitors

The capacitors dedicated to the DC/DC converter (decoupling for VDDP, or pump capacitors on SAP/SAM, SBP/SBM; and VUP), must be physically placed close to their dedicated pin.

In addition, the capacitors on VDDP and VUP must have a short and low resistive connection to the GNDC pin, which is the ground pin dedicated to the DC/DC converter.

10.2.3 Clock wires

Clock (card) or oscillator signals can cause crosstalk to other signals. It is advised to isolate these signals: make the connections as short as possible and keep them far from other signals.

The best is to shield these signals with ground when possible.

10.2.4 Card ground connection

Pin GNDC of the TDA8035 is dedicated to the smart card connector. It is advised to connect the C5 (GND) pin of the smart card connector to this pin before connecting it to the main ground.

But it is mandatory to have this pin always connected to the main ground of the board, as well as the card connector ground pin.

10.3 Summary

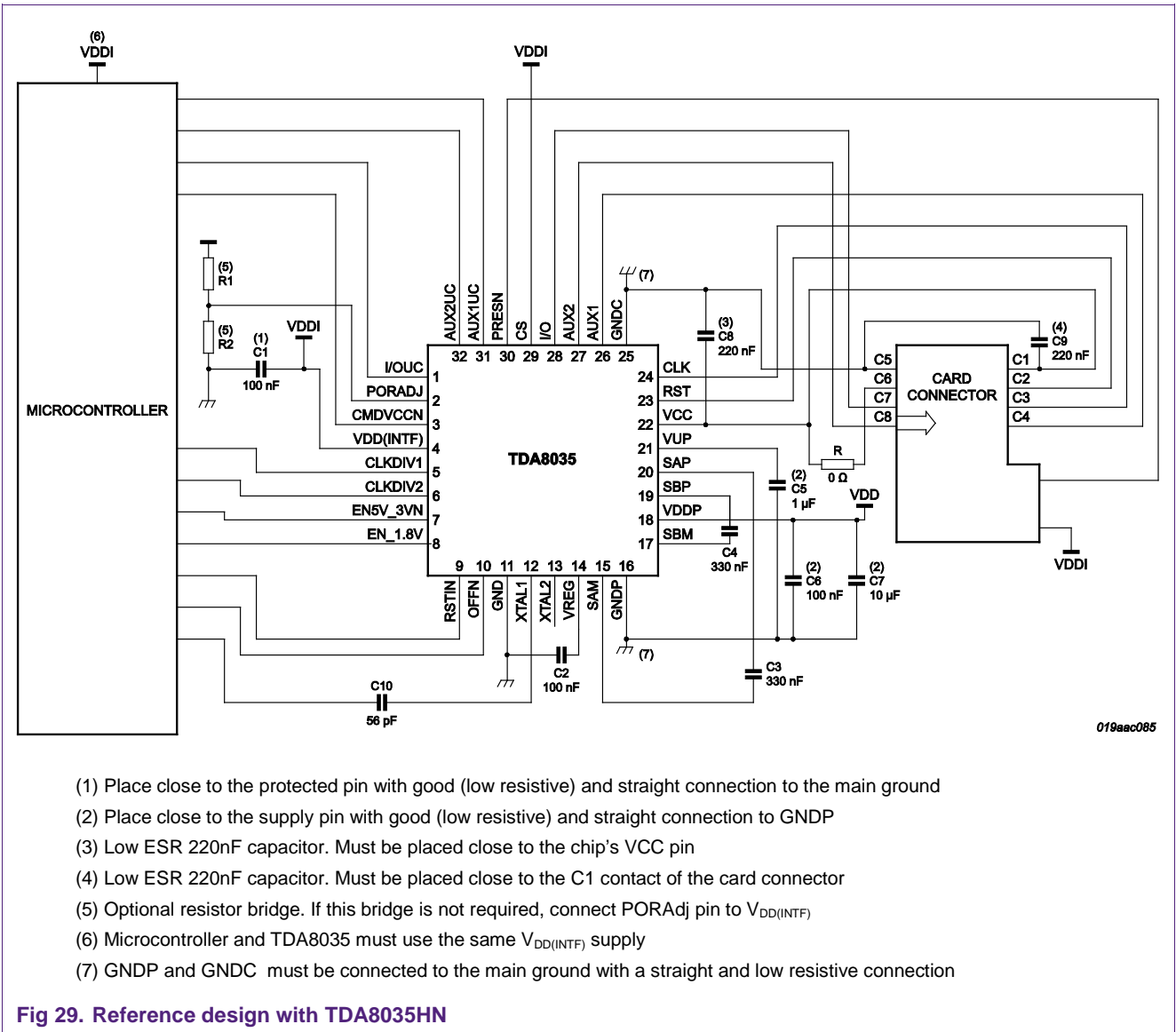

Fig 29. Reference design with TDA8035HN

11. Legal information

11.1 Definitions

Draft — The document is a draft version only. The content is still under internal review and subject to formal approval, which may result in modifications or additions. NXP Semiconductors does not give any representations or warranties as to the accuracy or completeness of information included herein and shall have no liability for the consequences of use of such information.

11.2 Disclaimers

Limited warranty and liability — Information in this document is believed to be accurate and reliable. However, NXP Semiconductors does not give any representations or warranties, expressed or implied, as to the accuracy or completeness of such information and shall have no liability for the consequences of use of such information. NXP Semiconductors takes no responsibility for the content in this document if provided by an information source outside of NXP Semiconductors.

In no event shall NXP Semiconductors be liable for any indirect, incidental, punitive, special or consequential damages (including - without limitation - lost profits, lost savings, business interruption, costs related to the removal or replacement of any products or rework charges) whether or not such damages are based on tort (including negligence), warranty, breach of contract or any other legal theory.

Notwithstanding any damages that customer might incur for any reason whatsoever, NXP Semiconductors' aggregate and cumulative liability towards customer for the products described herein shall be limited in accordance with the *Terms and conditions of commercial sale* of NXP Semiconductors.

Right to make changes — NXP Semiconductors reserves the right to make changes to information published in this document, including without limitation specifications and product descriptions, at any time and without notice. This document supersedes and replaces all information supplied prior to the publication hereof.

Suitability for use — NXP Semiconductors products are not designed, authorized or warranted to be suitable for use in life support, life-critical or safety-critical systems or equipment, nor in applications where failure or malfunction of an NXP Semiconductors product can reasonably be expected to result in personal injury, death or severe property or environmental damage. NXP Semiconductors and its suppliers accept no liability for inclusion and/or use of NXP Semiconductors products in such equipment or applications and therefore such inclusion and/or use is at the customer's own risk.

Applications — Applications that are described herein for any of these products are for illustrative purposes only. NXP Semiconductors makes no representation or warranty that such applications will be suitable for the specified use without further testing or modification.

Customers are responsible for the design and operation of their applications and products using NXP Semiconductors products, and NXP Semiconductors accepts no liability for any assistance with applications or customer product design. It is customer's sole responsibility to determine whether the NXP Semiconductors product is suitable and fit for the

customer's applications and products planned, as well as for the planned application and use of customer's third party customer(s). Customers should provide appropriate design and operating safeguards to minimize the risks associated with their applications and products.

NXP Semiconductors does not accept any liability related to any default, damage, costs or problem which is based on any weakness or default in the customer's applications or products, or the application or use by customer's third party customer(s). Customer is responsible for doing all necessary testing for the customer's applications and products using NXP Semiconductors products in order to avoid a default of the applications and the products or of the application or use by customer's third party customer(s). NXP does not accept any liability in this respect.

Export control — This document as well as the item(s) described herein may be subject to export control regulations. Export might require a prior authorization from competent authorities.

Evaluation products — This product is provided on an "as is" and "with all faults" basis for evaluation purposes only. NXP Semiconductors, its affiliates and their suppliers expressly disclaim all warranties, whether express, implied or statutory, including but not limited to the implied warranties of non-infringement, merchantability and fitness for a particular purpose. The entire risk as to the quality, or arising out of the use or performance, of this product remains with customer.

In no event shall NXP Semiconductors, its affiliates or their suppliers be liable to customer for any special, indirect, consequential, punitive or incidental damages (including without limitation damages for loss of business, business interruption, loss of use, loss of data or information, and the like) arising out of the use of or inability to use the product, whether or not based on tort (including negligence), strict liability, breach of contract, breach of warranty or any other theory, even if advised of the possibility of such damages.

Notwithstanding any damages that customer might incur for any reason whatsoever (including without limitation, all damages referenced above and all direct or general damages), the entire liability of NXP Semiconductors, its affiliates and their suppliers and customer's exclusive remedy for all of the foregoing shall be limited to actual damages incurred by customer based on reasonable reliance up to the greater of the amount actually paid by customer for the product or five dollars (US\$5.00). The foregoing limitations, exclusions and disclaimers shall apply to the maximum extent permitted by applicable law, even if any remedy fails of its essential purpose.

11.3 Trademarks

Notice: All referenced brands, product names, service names and trademarks are property of their respective owners.

12. List of figures

Fig 1.	Simplified interfacing view.....	3
Fig 2.	Supply supervisor principles	5
Fig 3.	$V_{DD(INTF)}$ supervision – PORADJ level detector .	6
Fig 4.	$V_{DD(INTF)}$ supervision – Reset when PORADJ falls	6
Fig 5.	$V_{DD(INTF)}$ supervision – Resistor bridge	7
Fig 6.	$V_{DD(INTF)}$ supervision – Virtual $V_{DD(INTF)}$ threshold V_{th}	7
Fig 7.	$V_{DD(INTF)}$ supervision – No resistor bridge.....	8
Fig 8.	DC/DC converter capacitors	9
Fig 9.	Deep shutdown mode example.....	11
Fig 10.	TDA8035 clock.....	12
Fig 11.	Input clock not centered on $V_{DD(INTF)}/2$	13
Fig 12.	XTAL1 serial capacitor	14
Fig 13.	Input clock after serial capacitor correction – Output Duty cycle ~ 50%	15
Fig 14.	CS action on CMDVCCN behavior	16
Fig 15.	CS action on OFFN behavior.....	17
Fig 16.	2 cascaded TDA8035 devices	18
Fig 17.	2 devices management with CS.....	19
Fig 18.	Presence input pin	20
Fig 19.	Normally closed card connector connection....	20
Fig 20.	Normally closed card connector connection....	21
Fig 21.	Debouncing feature.....	22
Fig 22.	Card connector schematics.....	23
Fig 23.	Clock switch during activation	26
Fig 24.	Unwanted frequency during the switch	27
Fig 25.	Card activation sequence.....	28
Fig 26.	Activation timing.....	29
Fig 27.	Deep shutdown, card extraction – OFFN behavior	33
Fig 28.	Power supply decoupling strategy	34
Fig 29.	Reference design with TDA8035HN	36

13. List of tables

Table 1. V_{DD(INTF)} referenced pins4
Table 2. Supply supervisor - Typical threshold values....8
Table 3. Select voltage pin behavior24
Table 4. TDA8035 - Clock division selection.....25
Table 5. Chip state regarding CMDVCCN and OFFN...32

14. Contents

1. Introduction	3	7.3	Deactivation.....	30
1.1 Presentation	3	8. Card operation	31	
2. Power supply	4	8.1 I/O, Aux1, Aux2	31	
2.1 Power supply pins	4	8.2 Warm reset.....	31	
2.2 Supply supervisor.....	5	9. OFFN Behavior	32	
2.2.1 Main principles	5	9.1 Fault detection.....	32	
2.2.2 Supervision with PORAdj used	6	9.2 Deep shutdown specific behavior	33	
2.2.3 Summary.....	8	10. Electrical design recommendations	34	
2.3 DC/DC Converter	8	10.1 Decoupling	34	
2.3.1 Schematics.....	8	10.2 Layout.....	34	
2.3.2 Layout	10	10.2.1 Decoupling capacitors	34	
2.4 Low consumption	10	10.2.2 DC/DC capacitors.....	35	
2.4.1 Shutdown mode	10	10.2.3 Clock wires	35	
2.4.2 Deep shutdown mode	10	10.2.4 Card ground connection	35	
3. Input Clock	12	10.3 Summary	36	
3.1 Clock selection	12	11. Legal information	37	
3.2 Duty cycle.....	13	11.1 Definitions.....	37	
4. Chip select	16	11.2 Disclaimers.....	37	
4.1 Active device	16	11.3 Trademarks	37	
4.2 Schematics.....	18	12. List of figures	38	
4.3 Device switch	19	13. List of tables	39	
5. Card connector	20	14. Contents	40	
5.1 Presence pin	20			
5.1.1 Normally closed presence switch	20			
5.1.2 Normally open presence switch	20			
5.1.2.1 Schematics.....	20			
5.1.2.2 Pull-up resistor calculation	21			
5.1.3 Debouncing	22			
5.2 Schematics.....	23			
6. Card configuration	24			
6.1 Card voltage.....	24			
6.2 Card clock	25			
6.2.1 Frequency selection	25			
6.2.2 Frequency switch	26			
6.2.2.1 General behavior.....	26			
6.2.2.2 Simultaneous change on CLKDIV1 and CLKDIV2	26			
7. Card Activation / Deactivation	27			
7.1 Difference TDA8024 – TDA8035.....	27			
7.1.1 Activation timing.....	27			
7.1.2 Software.....	27			
7.1.3 Test Mode / IOUC	27			
7.2 Activation.....	28			
7.2.1 Timings	28			
7.2.2 IOUC / Test Mode	30			

Please be aware that important notices concerning this document and the product(s) described herein, have been included in the section 'Legal information'.